

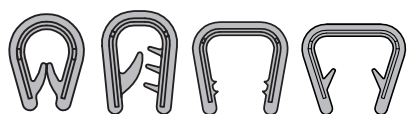

21

GUARNIZIONI LINEARI





**Profili copri bordo con anima metallica**

*pag. 21.1*

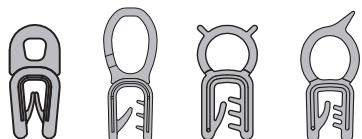

**Guarnizioni palloncino frontale e anima metallica**

*pag. 21.2*

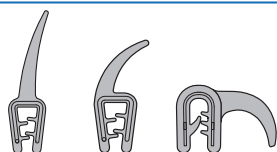

**Guarnizioni con baffo e anima metallica**

*pag. 21.3*



**Guarnizioni palloncino laterale e anima metallica**

*pag. 21.4*



**Profili gomma morbida con adesivo**

*pag. 21.5*

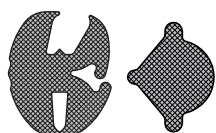

**Profili per vetri**

*pag. 21.6*

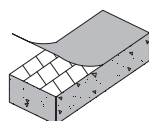

**Mousse autoadesiva a cellule chiuse retinata**

*pag. 21.7*

TIPO 1

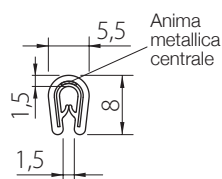

TIPO 2

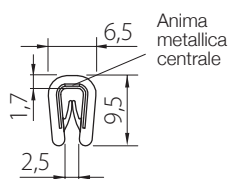

TIPO 3

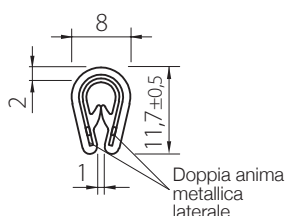

TIPO 4

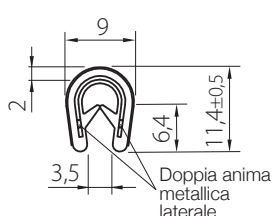

TIPO 5

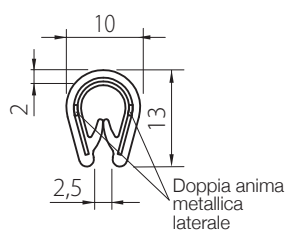

TIPO 6

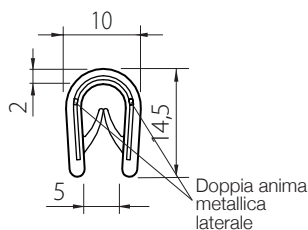

TIPO 7

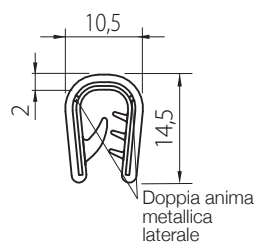

TIPO 8

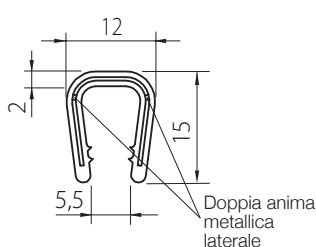

TIPO 9

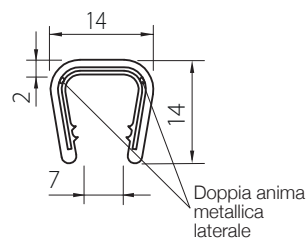

TIPO 10

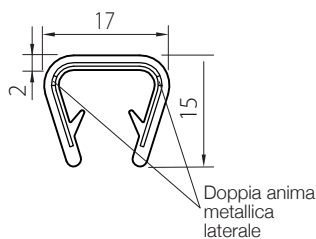
**MATERIALE**

Profilo: PVC (Cloruro polivinilico)

Anima metallica: AA (Acciaio armonico)

**COLORE**

Vedi tabella

**DUREZZA**

78 Shore A (±5)

**CERTIFICAZIONI**

UNI CEI 11170-3

EN 45545 solo per EPDM

**TOLLERANZE**

Secondo DIN 7715 M4

**NOTE**

\*Su richiesta fornibile anche in colore: antracite, grigio chiaro, bianco sporco.

Codice	Colore	Spessore lamiera	Tipo	Confezione (mt)
GZLBP000001N8	NE Nero	0,8-1,5	1	100
GZLBP000002N8	NE Nero	1,0-2,0	2	100
GZLBP000003N9	BI Bianco	1,0-2,0	2	100
GZLBP000004P0	AG Argento	1,0-2,0	2	100
GZLBP000005N8	NE Nero	1,0-2,5	3	100
GZLBP000006N8	NE Nero	2,0-4,0	4	100
GZLBP000007N8	NE Nero	1,0-4,0	5	100
GZLBP000008N8*	NE Nero	1,0-4,0	6	100
GZLBP000009N8	NE Nero	2,0-5,0	7	50
GZLBP000010N8	NE Nero	6,0-8,0	8	100
GZLBP000011N8	NE Nero	8,0-10,0	9	100
GZLBP000012N8	NE Nero	10,0-12,0	10	100

## MATERIALE TIPO ASSEMBLATO

Profilo autoagganciante: PVC (Cloruro polivinilico)  
Palloncino: EPDM espanso (spugna etilene propilene diene)  
Anima metallica: AA (Acciaio armonico)

## MATERIALE TIPO COESTRUSO

Profilo autoagganciante: EPDM (Gomma etilene propilene diene) 60 Shore A ( $\pm 5$ )  
Palloncino: EPDM espanso (spugna etilene propilene diene)  
\* Profilo autoagganciante: NBR (Gomma nitrilica)  
\* Palloncino: NBR espanso (spugna nitrilica)  
Anima metallica: AA (Acciaio armonico)

## COLORE

Nero

## CERTIFICAZIONI

UNI CEI 11170-3  
EN 45545 solo per EPDM

## TEMPERATURA DI ESERCIZIO EPDM IN CONDIZIONI ASCIUTTE

-50°C ÷ 120°C

## TEMPERATURA DI ESERCIZIO EPDM CON ACQUA E VAPORE

-50°C ÷ 130°C

## TEMPERATURA DI ESERCIZIO NBR

-20°C ÷ 100°C

## TOLLERANZE

Secondo DIN ISO 3302-1E2

## NOTE

Compressione consigliata per sigillare profili paraspigoli: 30-40%

TIPO 1

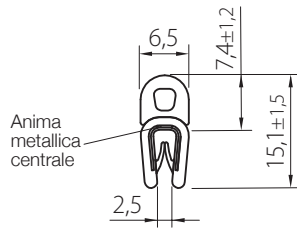

TIPO 2

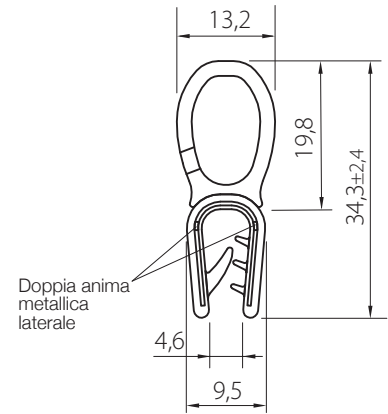

TIPO 3

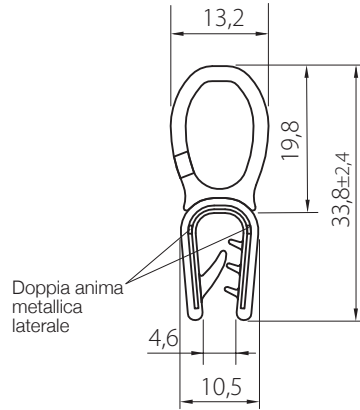

TIPO 4

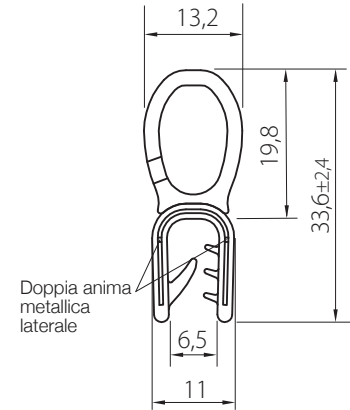

TIPO 5

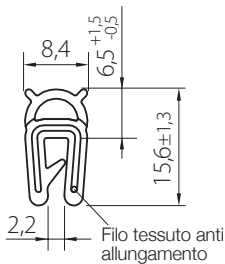

TIPO 6

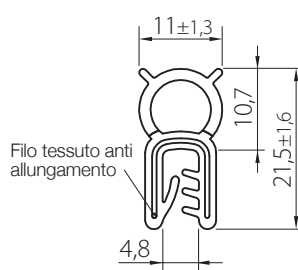

TIPO 7

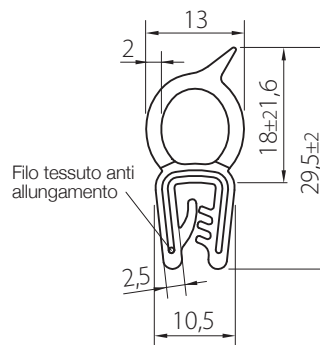

TIPO 8

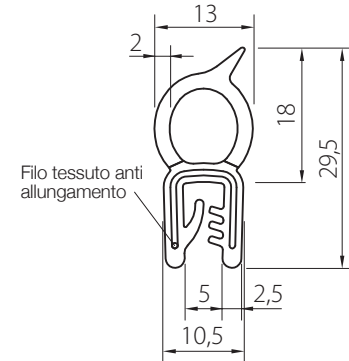

Codice	Spessore lamiera	Tipo	Confezione (mt)
GZLCPE00001N8	1,0-2,0	1 Assemblato	100
GZLCPE00002N8	1,0-2,5	2 Assemblato	50
GZLCPE00003N8	2,0-4,0	3 Assemblato	50
GZLCPE00004N8	4,0-6,0	4 Assemblato	50
GZLCE000005N8	1,0-2,0	5 Coestruso	100
GZLCE000006N8	1,0-3,0	6 Coestruso	100
GZLCN000007N8*	1,0-3,0	6 Coestruso	100
GZLCE000008N8	1,0-2,5	7 Coestruso	100
GZLCE000009N8	2,0-4,0	8 Coestruso	100

**TIPO 1**

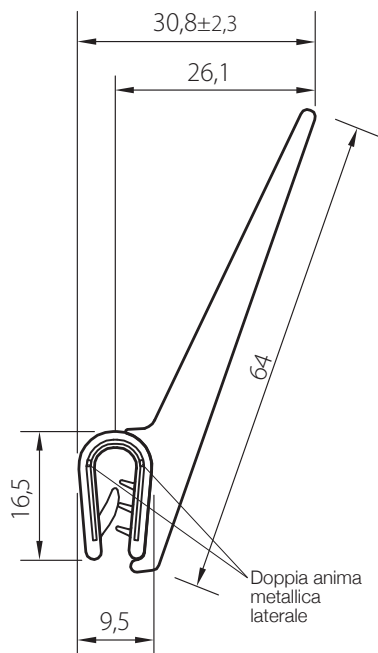

**TIPO 2**

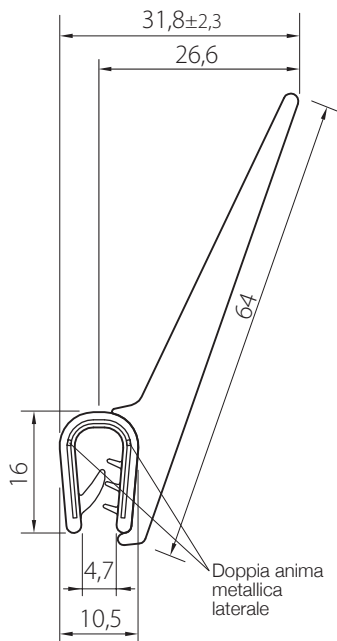

**TIPO 3**

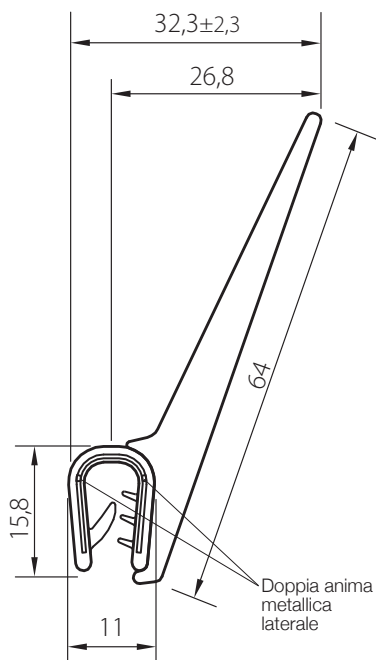

**TIPO 4**

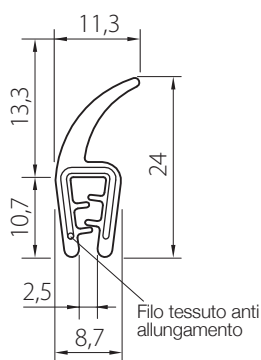

**TIPO 5**

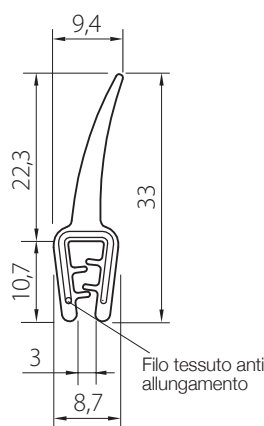

**TIPO 6**

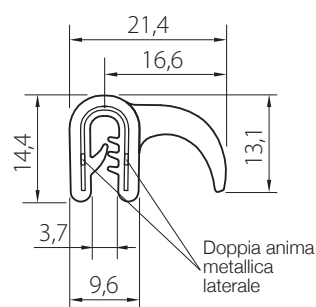

**MATERIALE TIPO ASSEMBLATO**

Profilo autoagganciante: PVC (Cloruro polivinilico)  
Baffo: EPDM espanso (spugna etilene propilene diene)  
Anima metallica: AA (Acciaio armonico)

**MATERIALE TIPO COESTRUSO**

\*\* Profilo e baffo: EPDM (Gomma etilene propilene diene)  
\* Profilo: EPDM (Gomma etilene propilene diene)  
\* Baffo: EPDM espanso (spugna etilene propilene diene)  
Anima metallica: AA (Acciaio armonico)

**COLORE**

**NE** Nero

**CERTIFICAZIONI**

UNI CEI 11170-3  
EN 45545 solo per EPDM

**TEMPERATURA DI ESERCIZIO EPDM IN CONDIZIONI ASCIUTTE**

-50°C ÷ 120°C

**TEMPERATURA DI ESERCIZIO EPDM CON ACQUA E VAPORE**

-50°C ÷ 130°C

**TOLLERANZE**

Secondo DIN ISO 3302-1 E3

Codice	Spessore lamiera	Tipo	Durezza profilo	Confezione (mt)
GZLFPE00001N8	1,0-2,0	1 Assemblato	-	25
GZLFPE00002N8	2,0-4,0	2 Assemblato	-	25
GZLFPE00003N8	4,0-6,0	3 Assemblato	-	25
GZLEE000001N8**	1,0-2,5	4 Coestruso	60 Shore A (±5)	150
GZLEE000002N8**	1,0-2,5	5 Coestruso	65 Shore A (±5)	50
GZLFE000004N8*	1,0-2,5	6 Coestruso	70 Shore A (±5)	100



## MATERIALE TIPO ASSEMBLATO

Profilo autoagganciante: PVC (Cloruro polivinilico)  
Palloncino: EPDM espanso (spugna etilene propilene diene)  
Anima metallica: AA (Acciaio armonico)

## MATERIALE TIPO COESTRUSO

Profilo autoagganciante: EPDM (Gomma etilene propilene diene)  
Palloncino: EPDM espanso (spugna etilene propilene diene)  
\* Profilo autoagganciante: NBR (Gomma nitrilica)  
\* Palloncino: NBR espanso (spugna nitrilica)  
Anima metallica: AA (Acciaio armonico)

## COLORE

**NE** Nero

## CERTIFICAZIONI

UNI CEI 11170-3  
EN 45545 solo per EPDM

## TEMPERATURA DI ESERCIZIO EPDM IN CONDIZIONI ASCIUTTE

-50°C ÷ 120°C

## TEMPERATURA DI ESERCIZIO EPDM CON ACQUA E VAPORE

-50°C ÷ 130°C

## TEMPERATURA DI ESERCIZIO NBR

-20°C ÷ 100°C

## TOLLERANZE

Secondo DIN ISO 3302-1 E2

## NOTE

Compressione consigliata per sigillare profili parasigilli: 30-40%

TIPO 1

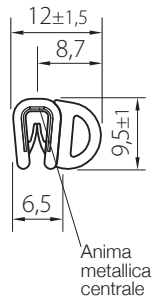

TIPO 2

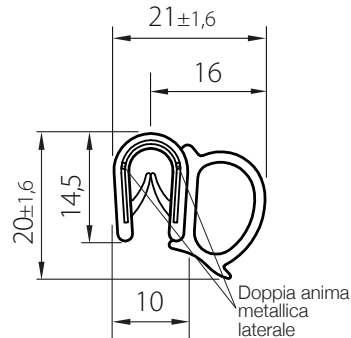

TIPO 3

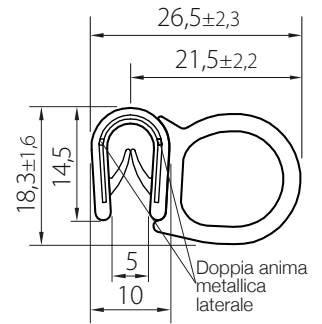

TIPO 4

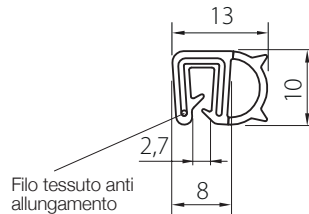

TIPO 5

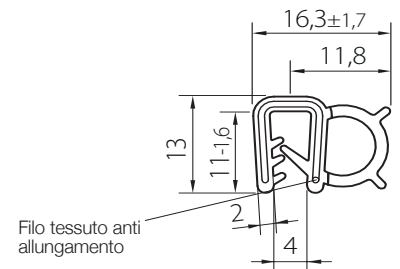

TIPO 6

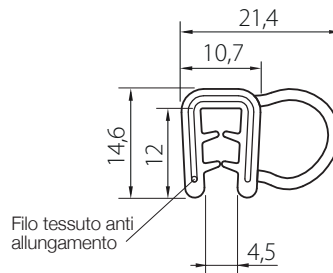

TIPO 7

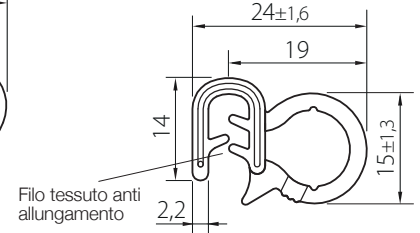

TIPO 8

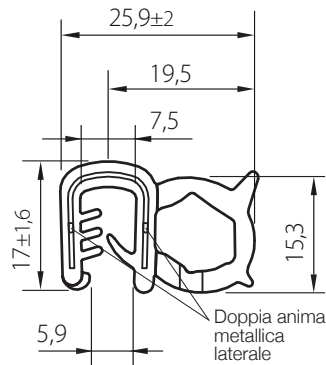

TIPO 9

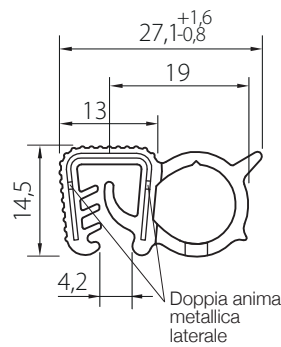

TIPO 10

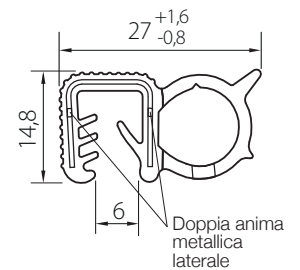

Codice	Spessore lamiera	Tipo	Durezza profilo	Confezione (mt)
GZLDPE00001N8	1,0-2,0	1 Assemblato	-	100
GZLDPE00002N8	1,0-4,0	2 Assemblato	-	50
GZLDPE00003N8	1,0-4,0	3 Assemblato	-	50
GZLDE000004N8	1,0-2,5	4 Coestruso	60 Shore A (±5)	100
GZLDE000005N8	2,0	5 Coestruso	65 Shore A (±5)	100
GZLDN000006N8*	2,0	5 Coestruso	-	100
GZLDE000007N8	1,5-3,0	6 Coestruso	65 Shore A (±5)	100
GZLDE000008N8	2,0-4,0	7 Coestruso	70 Shore A (±5)	50
GZLDE000009N8	5,0-6,0	8 Coestruso	65 Shore A (±5)	50
GZLDE000010N8	2,0-4,0	9 Coestruso	60 Shore A (±5)	75
GZLDE000011N8	5,0-6,0	10 Coestruso	65 Shore A (±5)	75

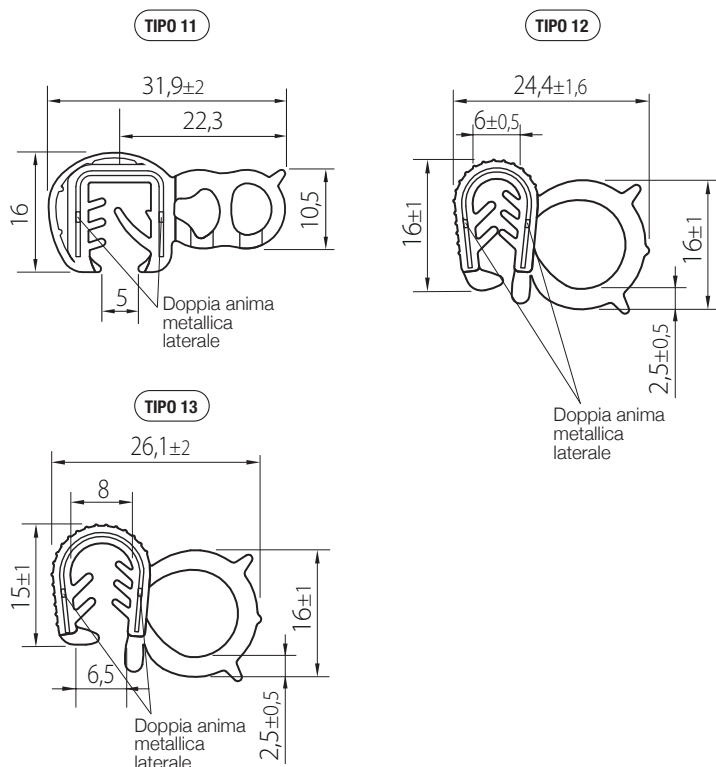

**MATERIALE TIPO COESTRUSO**

Profilo autoagganciante: EPDM (Gomma etilene propilene diene)  
Palloncino: EPDM espanso (spugna etilene propilene diene)  
\* Profilo autoagganciante: NBR (Gomma nitrilica)  
\* Palloncino: NBR espanso (spugna nitrilica)  
Anima metallica: AA (Acciaio armonico)

**COLORE**

Nero

**CERTIFICAZIONI**

UNI CEI 11170-3  
EN 45545 solo per EPDM

**TEMPERATURA DI ESERCIZIO EPDM IN CONDIZIONI ASCIUTTE**

-50°C ÷ 120°C

**TEMPERATURA DI ESERCIZIO EPDM CON ACQUA E VAPORE**

-50°C ÷ 130°C

**TEMPERATURA DI ESERCIZIO NBR**

-20°C ÷ 100°C

**TOLLERANZE**

Secondo DIN ISO 3302-1 E2

**NOTE**

Compressione consigliata per sigillare profili paraspigoli:  
30-40%

Codice	Spessore lamiera	Tipo	Durezza profilo	Confezione (mt)
GZLDE000010N8	2,0-4,0	11 Coestruso	60 Shore A (±5)	75
GZLDE000013N8	4,0-6,0	12 Coestruso	70 Shore A (±5)	25
GZLDE000014N8	2,0-4,0	13 Coestruso	70 Shore A (±5)	25

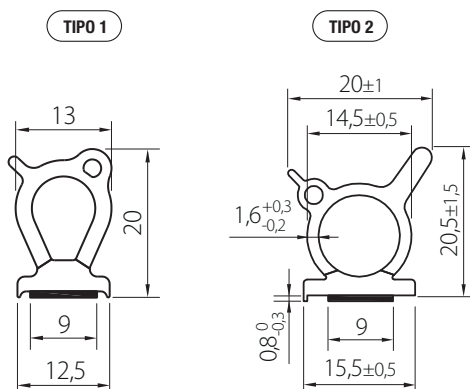

**MATERIALE**

Profilo: EPDM (Gomma etilene propilene diene)  
Palloncino: EPDM espanso (spugna etilene propilene diene)  
Adesivo: Schiuma acrilica

**COLORE**

Nero

**CERTIFICAZIONI**

UNI CEI 11170-3  
EN 45545

**TEMPERATURA DI ESERCIZIO EPDM IN CONDIZIONI ASCIUTTE**

-50°C ÷ 120°C

**TEMPERATURA DI ESERCIZIO EPDM CON ACQUA E VAPORE**

-50°C ÷ 130°C

**TOLLERANZE**

Secondo DIN ISO 3302-1 E3

Codice	Tipo	Larghezza adesivo	Durezza	Confezione (mt)
GZLHE000001N8	1	9	65 Shore A (±5)	125
GZLHE000002N8	2	9	75 Shore A (±5)	125



**MATERIALE**

EPDM espanso (spugna etilene propilene diene)  
Adesivo: Schiuma acrilica

**COLORE**

Nero

**CERTIFICAZIONI**

UNI CEI 11170-3  
EN 45545

**TEMPERATURA DI ESERCIZIO EPDM IN CONDIZIONI ASCIUTTE**

-50°C ÷ 120°C

**TEMPERATURA DI ESERCIZIO EPDM CON ACQUA E VAPORE**

-50°C ÷ 130°C

**TOLLERANZE**

Secondo DIN ISO 3302-1 E3

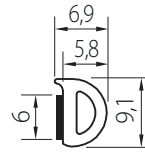
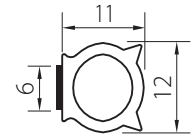
**TIPO 1**

**TIPO 2**

Codice	Tipo	Larghezza adesivo	Confezione (mt)
GZLHE000004N8	1	6	75
GZLHE000003N8	2	6	100

**PROFILI PER VETRI**
**GZLGE**
**MATERIALE**

Profilo: EPDM (Gomma etilene propilene diene)  
Anima di bloccaggio: EPDM (Gomma etilene propilene diene) 80 Shore A (±5)

**COLORE**

Nero

**CERTIFICAZIONI**

UNI CEI 11170-3  
EN 45545

**TEMPERATURA DI ESERCIZIO EPDM IN CONDIZIONI ASCIUTTE**

-50°C ÷ 120°C

**TEMPERATURA DI ESERCIZIO EPDM CON ACQUA E VAPORE**

-50°C ÷ 130°C

**TOLLERANZE**

Secondo DIN ISO 3302-1 E2

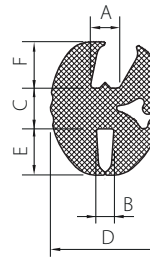
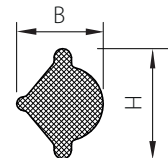
**Profilo**

**Anima di bloccaggio**

Codice profilo	Tipo profilo	A	B	C	D	E	F	Raggio di curvatura	Durezza	Confezione (mt)
GZLGE000001N8	1	3	2	4	10,2	3	3	80	65 Shore A (±5)	50
GZLGE000002N8	2	4	3	4	12,6	5	6	35	70 Shore A (±5)	25
GZLGE000003N8	3	5	3	7	19	8	8	90	65 Shore A (±5)	20

Codice anima di bloccaggio	Tipo profilo da abbinare	H	B	Confezione (mt)
GZLGE000004N8	1	5,5	4,5	50
GZLGE000005N8	2	7,0	6,0	50
GZLGE000006N8	3	9,5	7,5	50

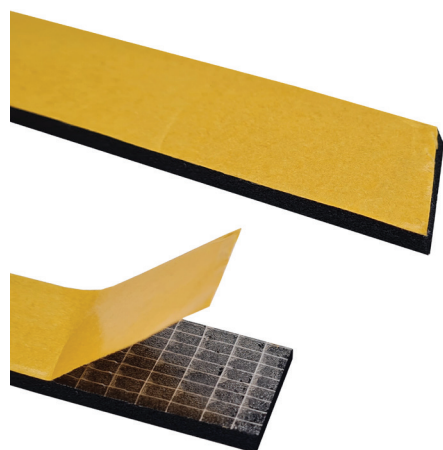



Retina

anti-allungamento

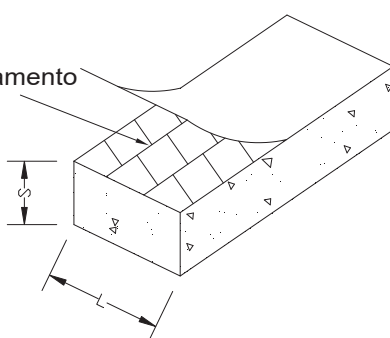
**MATERIALE**

EPDM (Gomma etilene propilene diene)

**COLORE**

Nero

**DUREZZA GOMMA**

25-45 Shore 00

**AUTOESTINGUENZA**

≥ sp. 9mm UL94 grado HBF, ≥ sp. 3mm FMVSS 302

**TEMPERATURA IN CONTINUO**

-40°C ÷ +100°C

**TEMPERATURA INTERMITTENTE**

120°C per 5 ore

**NOTE**

Fornibile in mescole speciali con certificazioni UL, EN45545 per il ferroviario o mescole per specifiche resistenze chimiche, invecchiamento, non proliferazione batterica.

Codice 	S	L	Confezione (mt)
GZLME000001N8	3	5	10
GZLME000002N8	3	10	10
GZLME000003N8	3	15	10
GZLME000004N8	3	20	10
GZLME000005N8	3	30	10
GZLME000006N8	3	40	20
GZLME000007N8	3	50	10
GZLME000008N8	5	5	10
GZLME000009N8	5	6	10
GZLME000010N8	5	10	10
GZLME000011N8	5	15	10
GZLME000012N8	5	20	10
GZLME000013N8	5	30	10
GZLME000014N8	5	40	10
GZLME000015N8	5	50	20
GZLME000016N8	10	10	10
GZLME000017N8	10	15	10
GZLME000018N8	10	20	10
GZLME000019N8	10	30	10
GZLME000020N8	10	40	10
GZLME000021N8	10	50	10
GZLME000022N8	15	15	5
GZLME000023N8	15	20	5
GZLME000024N8	15	30	5
GZLME000025N8	15	40	5
GZLME000026N8	15	50	5
GZLME000027N8	20	20	5
GZLME000028N8	20	30	5
GZLME000029N8	20	40	5
GZLME000030N8	20	50	5

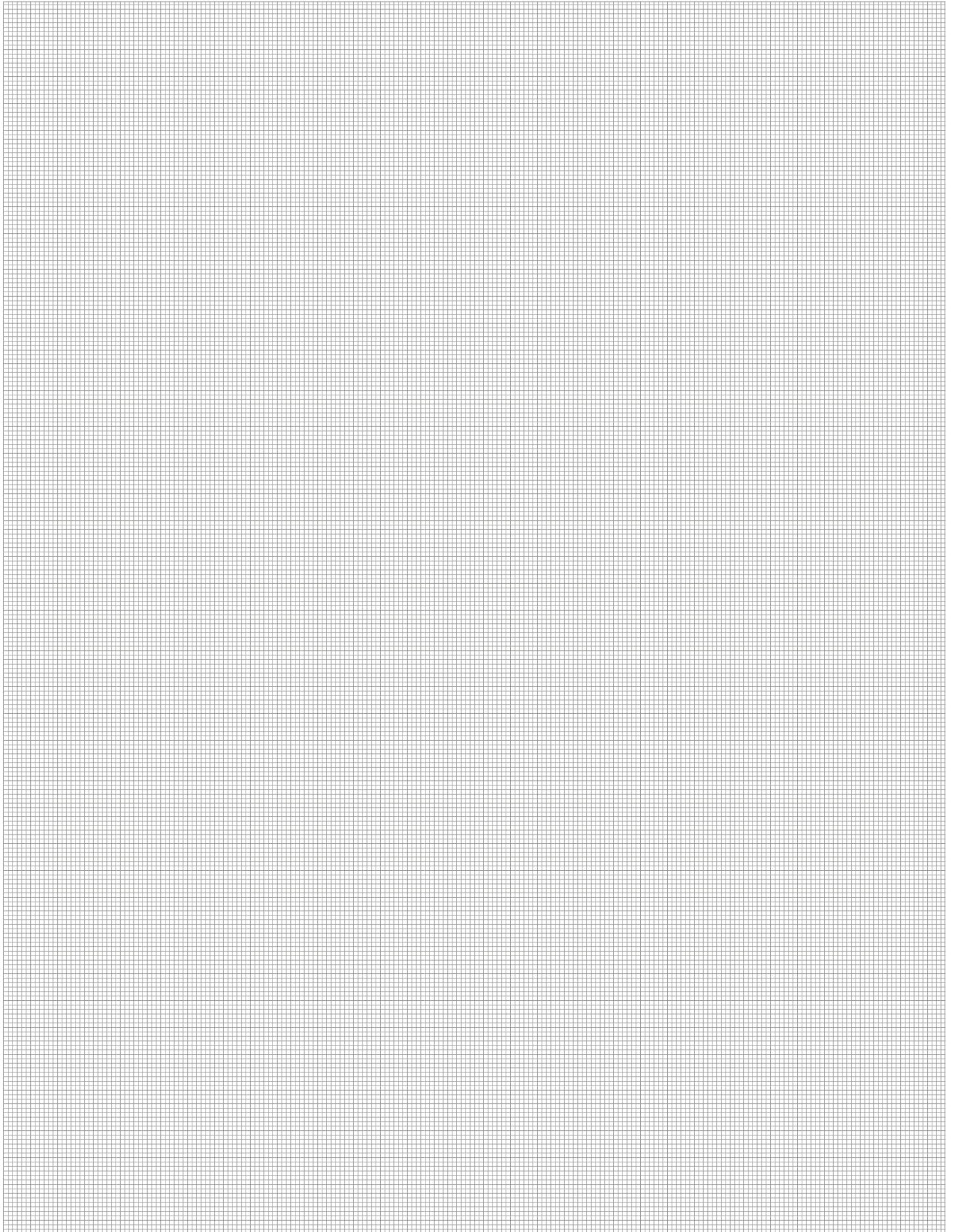

1

2

3

4

5

6

7

8

9

10

11

12

13

14

15

16

17

18

19

20

21



1
2
3
4
5
6
7
8
9
10
11
12
13
14
15
16
17
18
19
20
21

